



META RADIUS BLOCK

10" Radius Block for Advanced Conductors



UNMATCHED VERSATILITY

FLEXIBILITY With a rotating base and multiple mounts, our line stringer block adapts seamlessly to any project. Mount the MRB easily to poles and crossarms in a variety of configurations with our distribution or transmission models.



EFFICIENCY/ STRATEGY

Drone Stringing significantly improves efficiency by eliminating the myriad of issues with helicopters. A light spring in the gate allows seamless Drone Stringing and the non-conductive guide stick allows easy landing.



DURABILITY

Made of Quality Materials our stringing blocks boast superior tensile strength, creep resistance, and durability. Lightweight and non-conductive properties align directly with OSHA 1910.269 (1) (2)



SAFETY

Save Money with faster install, lightweight design, less sprains and strains. Block body made from non-conductive materials to help reduce arc flashes. Rollers designed to protect conductors from damage.

Products Co-Created with Lineworkers for Lineworkers

† Seekells Innovations

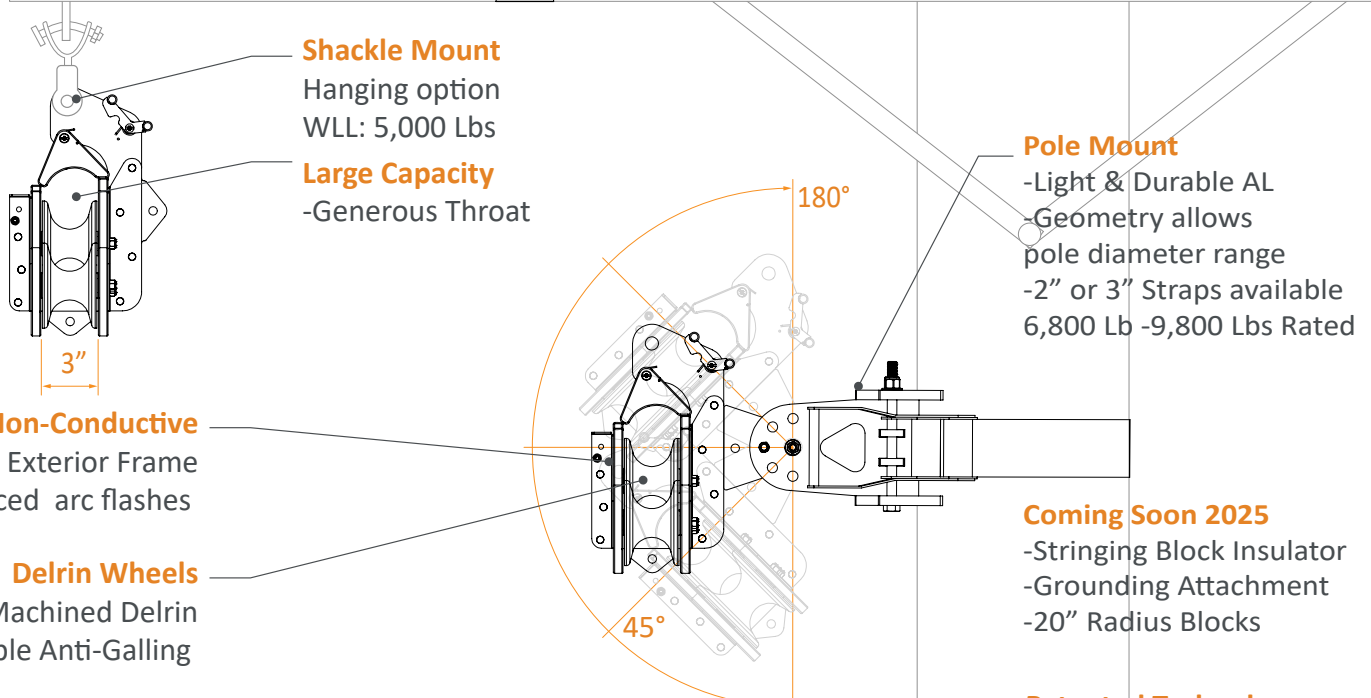
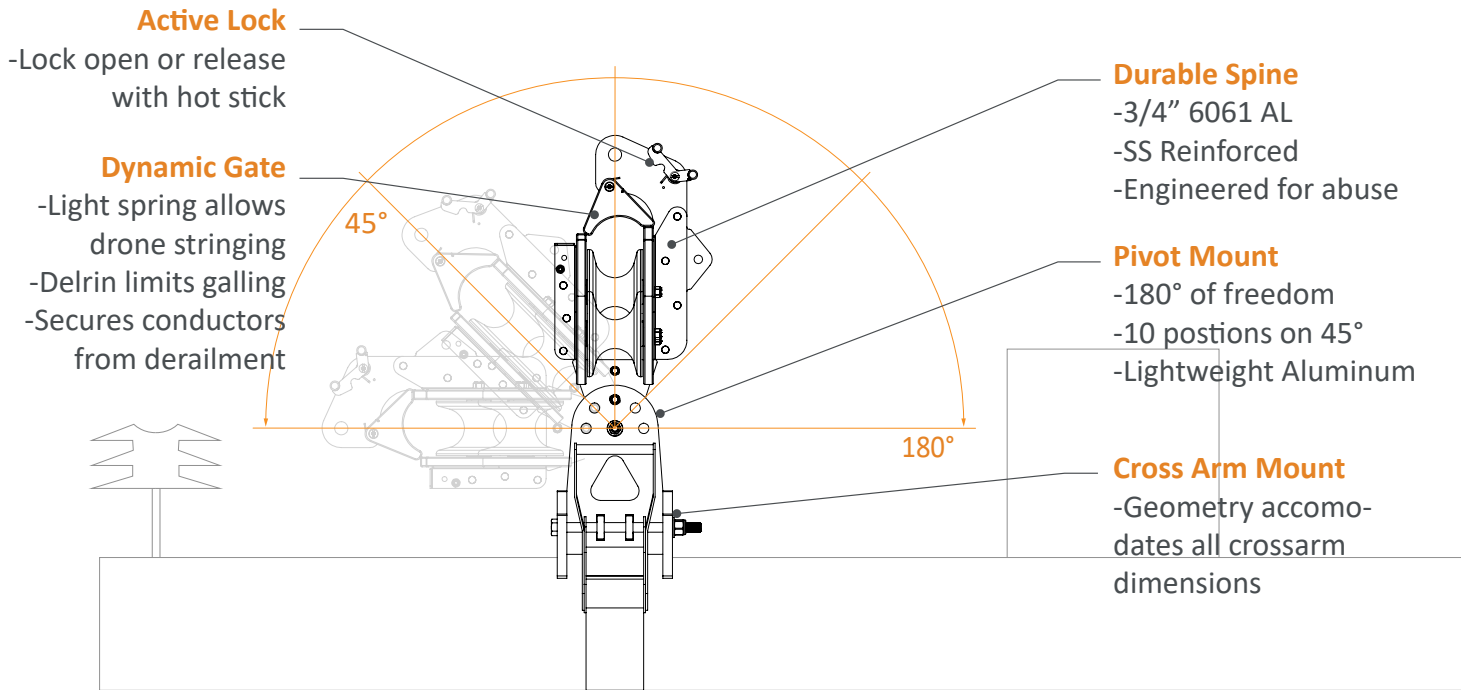

WORKING LOAD LIMIT:

Base Mounted: 2,500 Lbs

Shackle Mounted: 5,000 Lbs

[TESTED BY 3RD PARTY]

TOTAL WEIGHT: 13.5 Lbs

DIMENSIONS: 18" W x 8" D x 14.5" H

Coming Soon 2025

-Stringing Block Insulator

-Grounding Attachment

-20" Radius Blocks

Patented Technology

US Patent # 10,998,700

US Patent # 10,763,648

US Patent # 11,476,596

US Patent # 11,942,238

† seekells Innovations

MADE IN



SHORT LEAD TIME - SHIPS ANYWHERE IN U.S.A. CALL 888 817-7018