



POLE TRAILER & TRUCK SOLUTIONS

Co-Created for Linemen with Linemen



VERSATILITY & FLEXIBILITY

Custom configuration is easy. Designed for rapid installation and convenient re-positioning while handling a broad variety of tools and materials to your preference. Mounts to a variety of trailer models.



EFFICIENCY/ ERGONOMICS

Expedite projects by organizing components within easy grasp and reduce the time to mount or retrieve materials. No more straining to reach buried tools. No more lost time replacing or searching for inventory.

1172 Railroad Avenue, Vallejo, CA 94592
tel - 888.511.3101 - fax - 888.415.0645

METADESIGNMFG.COM



DURABILITY

Engineered for abuse Tested by linemen on site, all products can take the abuse of the most demanding projects.



SAFETY

Road safety is critical and secure containment of materials will minimize traffic incidents. The DPT will never bother you again. Mounting bulky, heavy items at arms reach reduce common back injuries.



ECONOMICAL

Proper organization of inventory reduces material costs. Ergonomic design reduces workman compensation costs.



REEL RACK A-FRAME
3-03-MPTA_RRAF

3000 lb Reel Capacity and up to 80" Dia. Supports all of the META Pole Trailer Accessories and allows for customization.
 Fits: Butler Trailer Series 600, 700, 1600
 W58"-65" X D3" X H40"

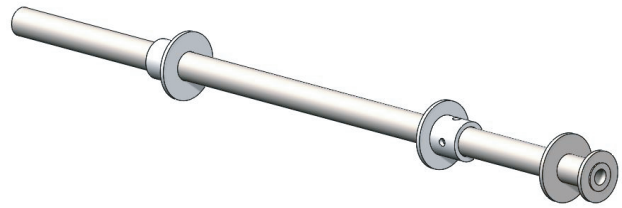

BAZOOKA MANDREL
3-03-MPTA_BM

6000 lb Reel Capacity and up to 80" Dia.
 Dia. 3" X L75"



POLE STAND
3-03-MPTA_PS

Prop up the power pole for convenient drilling and rigging.
 Mounts neatly on the trailer rail.
 W24" X D24" X H36"

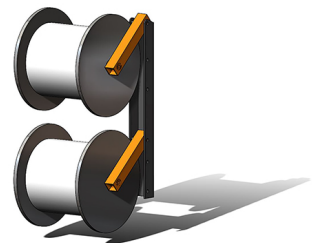

WIRE REEL RACK
3-03-MPTA_WRR

Position wire reels perpendicular to the street. Mounts two 10"-24" Reels. Gravity brake keeps wire tidy.

CALL or E-MAIL META FOR PRICING
intake@metadesignmfg.com 888 817-7018

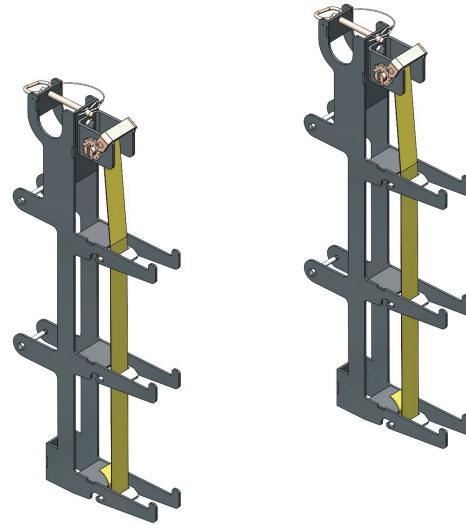

AMMO RACKS 3-03-MPTA_CAR

Cross Arm Racks. Secures up to **6 composite or wood cross arms** (All varieties and sizes complete with bulky brackets) using a **patent pending** ratcheting strap system. No more back injuries retrieving heavy items from the bottom of your trailer. W3" X D16" X H36"



TONGUE BOX 3-03-MPTA_TB

Properly secure gear to the trailer tongue. Mesh walls allow visibility for rapid location of materials. W36" X D24" X H16"



SHORT LEAD TIME - SHIPS ANYWHERE IN U.S.A. CALL 888 817-7018

1172 Railroad Avenue, Vallejo, CA 94592 tel - 888.817.7018 - fax - 888.817.7029 METADESIGNMFG.COM

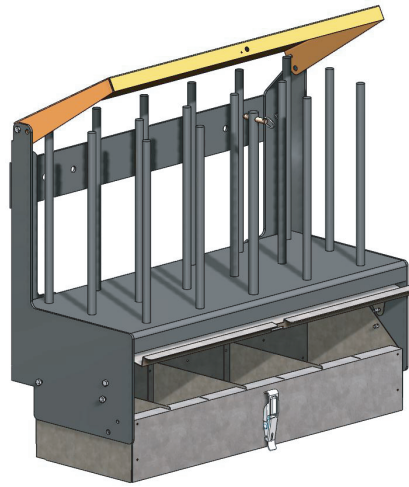

VAULT
3-03-MPTA_WRN5
Washer Rack and Nail Bin.
Organize and secure your money clips, washers, nails, staples, and so much more
W29" X D13" X H26"

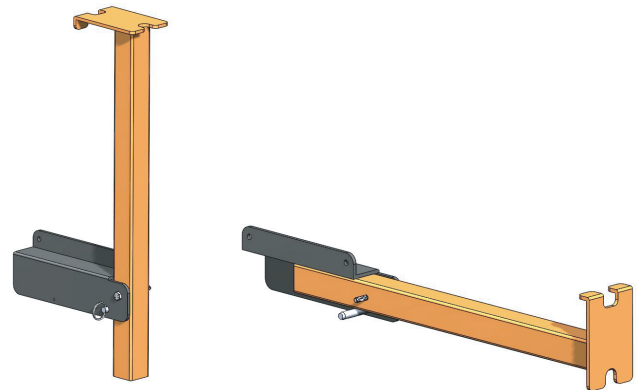

TALONS
3-03-MPTA_CASB
Cross Arm Staging Brace.
Convenient ergonomic support for working on cross arms and cutouts.
L25"

CALL or E-MAIL META FOR PRICING
intake@metadesignmfg.com 888 817-7018

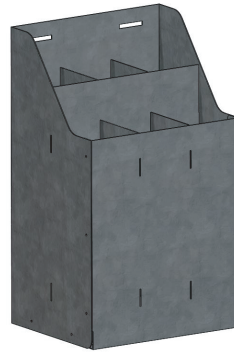

BOLT BIN
3-03-MPTA_BB

Organize up to 50lbs of bolts
Ideally for 12" - 20" long bolts
W10" X D8" X H17"

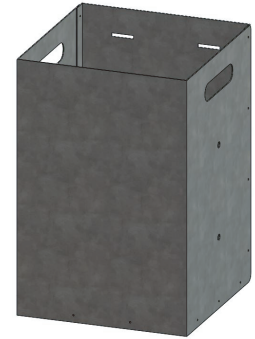

INSULATOR BIN
3-03-MPTA_IB

Big bin for odd shaped insulators,
rubbish, or just about anything.
W12" X D12" X H18"

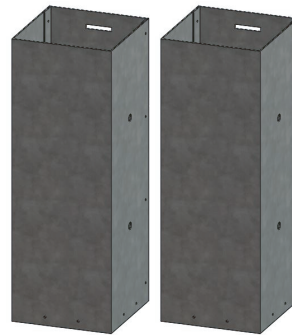
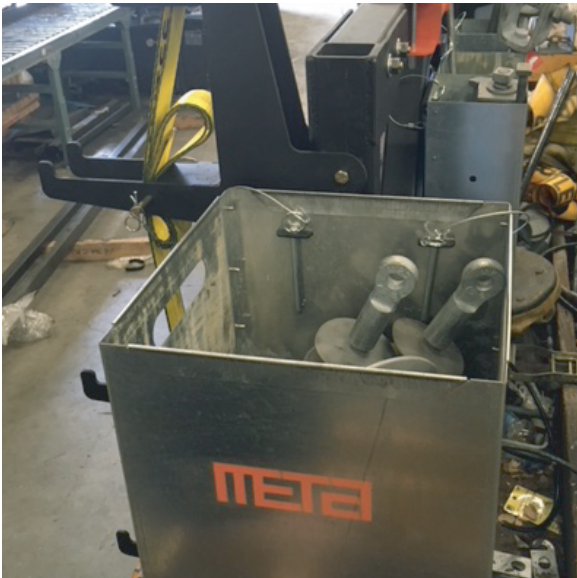

PREFORM BIN PAIR
3-03-MPTA_PBP

For long bolts, preforms, and tall
skinny stuff.
W6" X D6" X H18"



BIN BRACKET
3-02-MPTA_CBB

Mounts all bins with quick release pins.
Bolts to the A-Frame in a variety of
locations to allow custom positioning
W7.6" X D1.5" X H16.25"

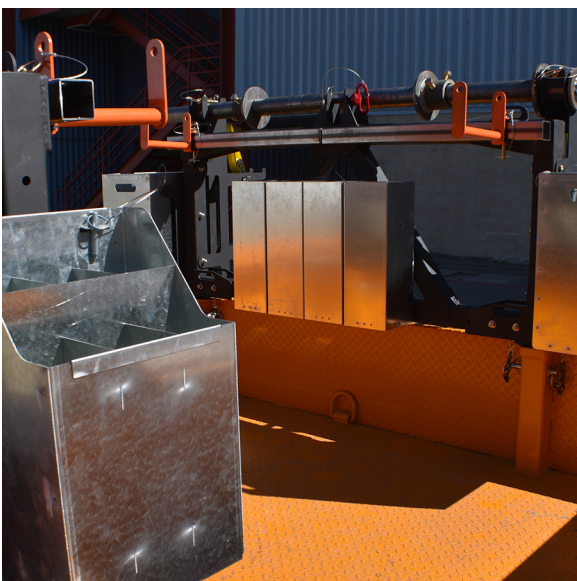

SHORT LEAD TIME - SHIPS ANYWHERE IN U.S.A. CALL 888 817-7018

1172 Railroad Avenue, Vallejo, CA 94592 tel - 888.817.7018 - fax - 888.817.7029 METADESIGNMFG.COM

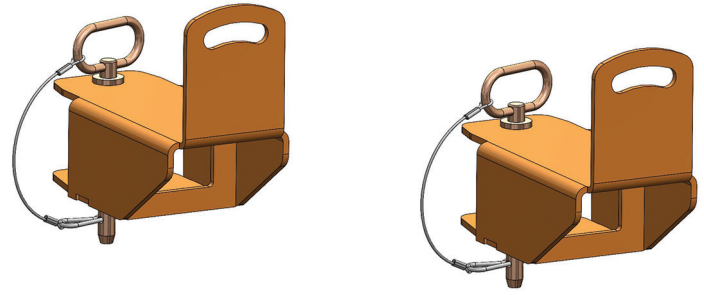

HANDY HOOKS
3-03-MPTA_HCH

Hand Coil Hooks. **400 Lb capacity** conveniently position anywhere on the **A-Frame Reel Rack** and quickly stow out of the way.
L10"

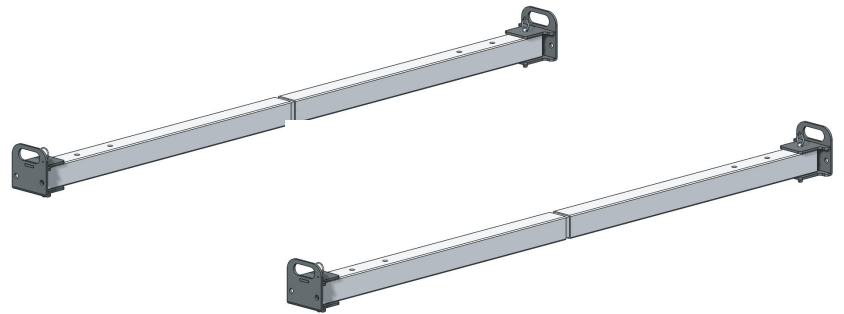

BUNYAN RACKS
3-03-MPTA_BR

Lumber racks with **1000 Lb capacity** conveniently position in place for carrying switch crates, cutoffs, or lumber while quickly stowing out of the way.
L60"-65"

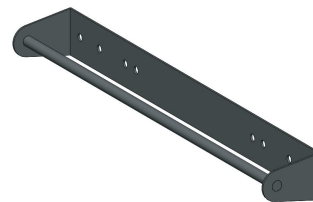

PRE-FORM RACK
3-03-MPTA_PFR

Hang countless pre-forms and insulators from this sturdy 5/8" rod. Position 2 side by side or center 1 on the A-frame.
L29"

CALL or E-MAIL META FOR PRICING
intake@metadesignmfg.com 888 817-7018

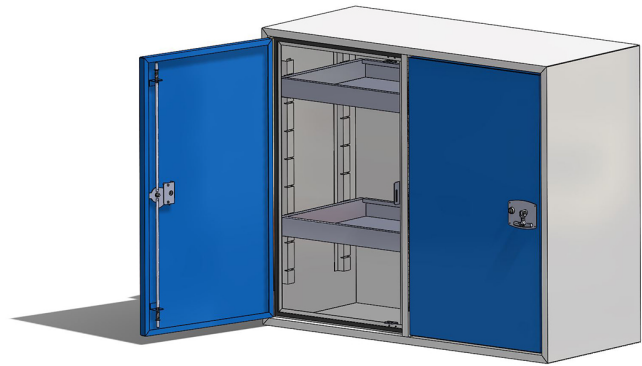

TRUCK TOOL CABINETS 3-03-TTB_A

Our tool cabinets offer superior strength and security with multi-point lock systems, available in a variety of sizes. Our team is always available for your **custom designs**.

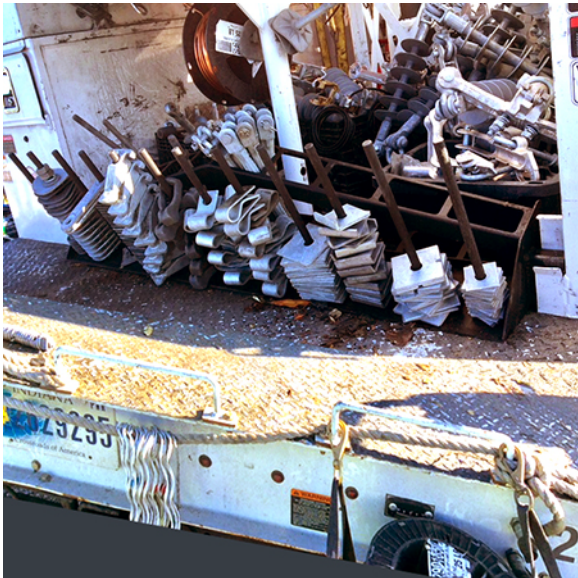

TAILGATE WASHER RACK 3-01-TGWR_7

Replace that useless piece of wood with a multi-function tailgate that stores all your washers, money clips, bolts and so much more. If you have a better idea, our team is always available for your **custom designs**.



BUCKET TRUCK BOXES 3-03-BTB_7

Our tool boxes come in lengths up to 7' and offer superior strength and security. Designed specifically for Bucket/Boom trucks, these boxes are perfect for stowing line hose, hotsticks and so much more. Available in a variety of sizes. Our team is always available for your **custom designs**.

META SOLUTIONS

We are continuously developing new products and solutions so if you don't see it here, we may still have it. Our team is always available for your **custom designs**.

SHORT LEAD TIME - SHIPS ANYWHERE IN U.S.A. CALL 888 817-7018

1172 Railroad Avenue, Vallejo, CA 94592 tel - 888.817.7018 - fax - 888.817.7029 METADESIGNMFG.COM

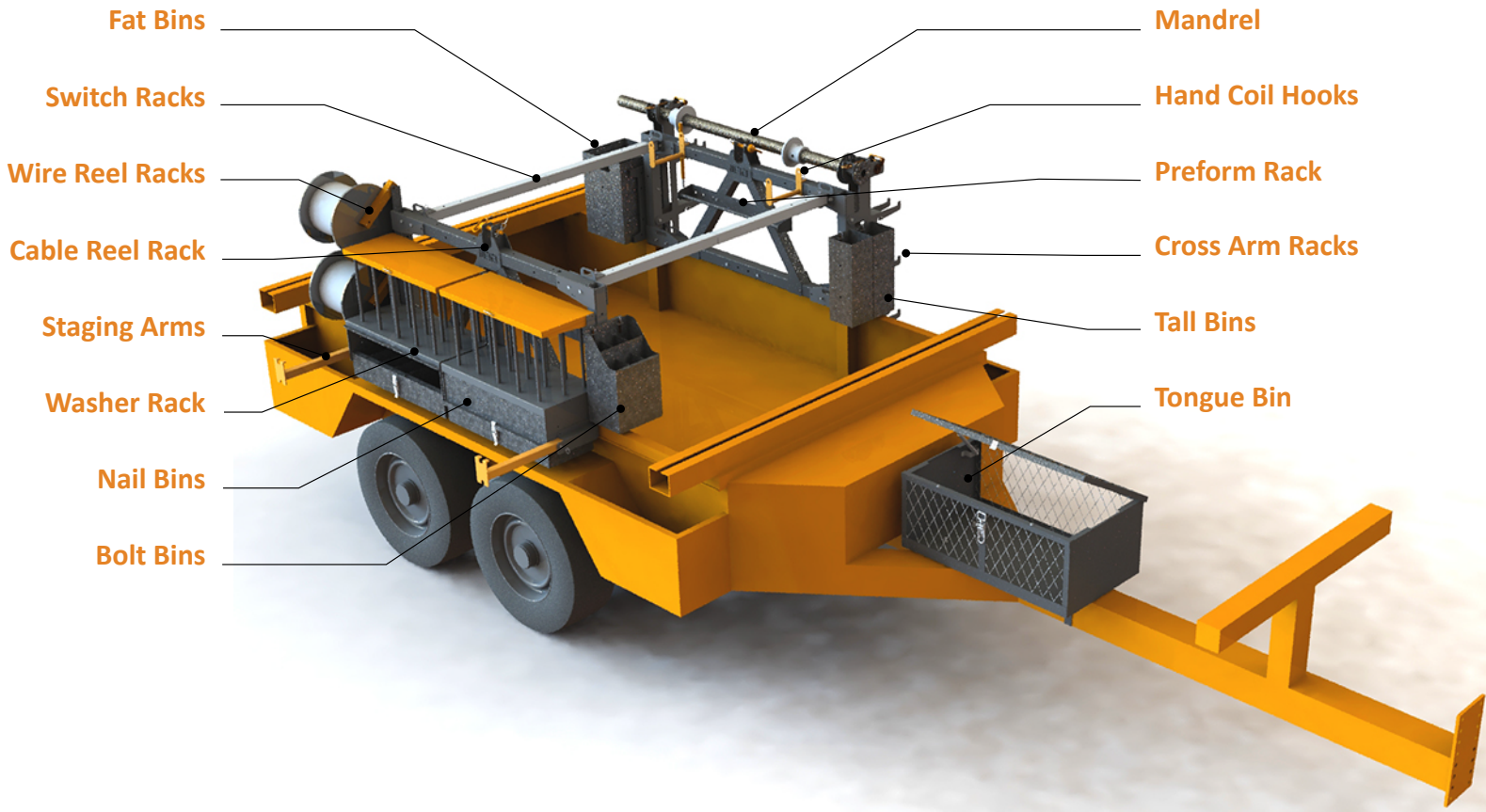

1172 Railroad Avenue, Vallejo, CA 94592
 tel - 888.511.3101 - fax - 888.415.0645
INTAKE@METADESIGNMFG.COM

LINEMAN CREW PACKAGE

Everything needed for optimal, security, ergonomics, & efficiency

REEL RACKS

Frame mounts all components while supporting up to a **6000Lb, 80" Dia reel**. Fits Butler series 600S, 700, and 1600 Trailers.

AMMO RACKS

Secures up to **6 composite or wood cross arms** (complete with mounting brackets) using a **3,000 lb rated ratcheting strap system**.

WASHER RACKS & NAIL BINS

Easily secures and organizes upwards of **800Lbs / 500 brackets**, washers & clips of every shape & size. Secures **6sq ft** of tools and small items like nails & staples.

STAGING ARMS

Holds cross arms and cut-outs in optimal position for preparation.

HAND COIL HOOKS

Swing arms hold up to **300lbs of wire coils** and swing out of the way of when not in use.

BOLT BINS

Qty: 2 (12" X 12" X 24" H) Qty: 4 (6" X 6" X 24" H)

Mounts with rapid release pins for convenient positioning

